

BROADWATER COUNTY COMMISSIONERS
515 Broadway, Townsend
Meetings are held at the Flynn Building on 416 Broadway St.

Current and previously recorded meetings, official agenda, and minutes may be viewed on the website at <https://www.broadwatercountymt.com>.

Per Montana Code Annotated (MCA) 2-3-202, agenda must include an item allowing public comment on any public matter that is not on the agenda of the meeting and that is within the jurisdiction of the agency conducting the meeting. Public comments will be taken either in writing before the meeting or in person at the beginning of the meeting. Mail and items for discussion and/or signature may occur as time allows during the meeting. Issues and times are subject to change. Working meetings will be posted on the agenda and will not be recorded.

OFFICIAL agendas are posted in the Courthouse (1st floor bulletin board), on our website at www.broadwatercountymt.com, in the window of the Flynn Building at least 48 hours in advance of the meeting, and in the Helena Independent Record (IR).

**COUNTY OFFICES WILL BE CLOSED ON MONDAY, OCTOBER 9, 2023 IN
OBSERVANCE OF COLUMBUS DAY**

Wednesday, October 4, 2023

- | | |
|-----------------|--|
| 10:00 AM | Public Comment on any subject not on the agenda, and that the Commission has jurisdiction over |
| 10:00 AM | Discussion, Jessica Bushnell, Department Update and Season Wrap-up |
| 10:10 AM | Discussion/Decision, TJ Graveley, Public Works Supervisor, Purchase of Fast-12T Radar Speed Trailer Request |
| 10:15 AM | Discussion/Decision, Newspaper RFP (Request for Proposal) |

Thursday, October 5, 2023

- | | |
|-----------------|--|
| 10:00 AM | Weekly Working Meeting with Jania Hatfield, Deputy County Attorney, in the Commission Office regarding projects and deadlines |
|-----------------|--|

Public Meeting Notices

- | | |
|----------------|---|
| 6:00 PM | <u>Oct. 11th</u> Southern Broadwater County: (CTAP*) Meeting at Bridger Brewing |
| 6:00 PM | <u>Oct. 12th</u> Northern Broadwater County: (CTAP*) Meeting at the Flynn Building |
| 6:00 PM | <u>Nov. 8th</u> Southern Broadwater County: (CTAP*) Meeting at Bridger Brewing |
| 6:00 PM | <u>Nov. 14th</u> Northern Broadwater County: (CTAP*) Meeting at the Flynn Building |

Discussion Regarding Future Growth in Broadwater County
Community Technical Assistance Program

Items for Discussion / Action / Review / Signature – Consent Agenda

- ✓ Certificate of Survey review
- ✓ Management – on-going advisory board appointments
- ✓ Claims/Payroll/minutes
- ✓ County Audit / Budget
- ✓ Mail – ongoing grants
- ✓ Correspondence – support letters

Debi Randolph, Chairman (406) 266-9270 or (406) 980-2050

Darrel Folkvord, Vice Chairman (406) 266-9272 or (406) 980-1213

Lindsey Richtmyer (406) 266-9271 or (406) 521-0834

E-mail: commissioners@co.broadwater.mt.us

Future Meetings will be held at the Flynn Building (416 Broadway)

(Please note: These meeting times/dates may change, please check the county website)

The Commissioners may be attending these board meetings (except the Planning Board)

- Trust Board on October 10 at 11:30 AM
- BC Planning Board on October 10 at 1 PM
- LAC Board on October 11 at 2 PM
- BC Parks & Rec on October 16 at 6 PM
- Weed Board on October 17th at 7 PM
- BC Airport Board on October 18 at 6 PM
- Broadband Advisory on October 26 at 4 PM

FAST-12T

Radar Speed Trailer

Product Applications

The FAST-12T Radar Speed Display Trailer was designed for residential street and corporate campus-type applications where speeding is a problem. While it may be light in weight, it is built to the same tough industrial standards as its bigger brothers. Easily towed with a passenger vehicle, the trailer can be repositioned throughout a community's streets for maximum effectiveness.

This trailer-mounted radar display is accurate within one mile per hour and easily read at a glance. The 12" high, full-matrix LED characters alert drivers of their speed from up to 750 feet away. Optional violator alerts help capture drivers' attention and inform them of their high speed.

Features and Benefits

- High-intensity 12" radar speed display calms traffic on roads with posted speeds 45 mph or less
- Versatile power options including hardwire (AC) and solar/battery (DC) combinations
- 12" speed digits visible up to 750 feet away
- "YOUR SPEED" static sign plaque mounts to top-of-radar speed display enclosure

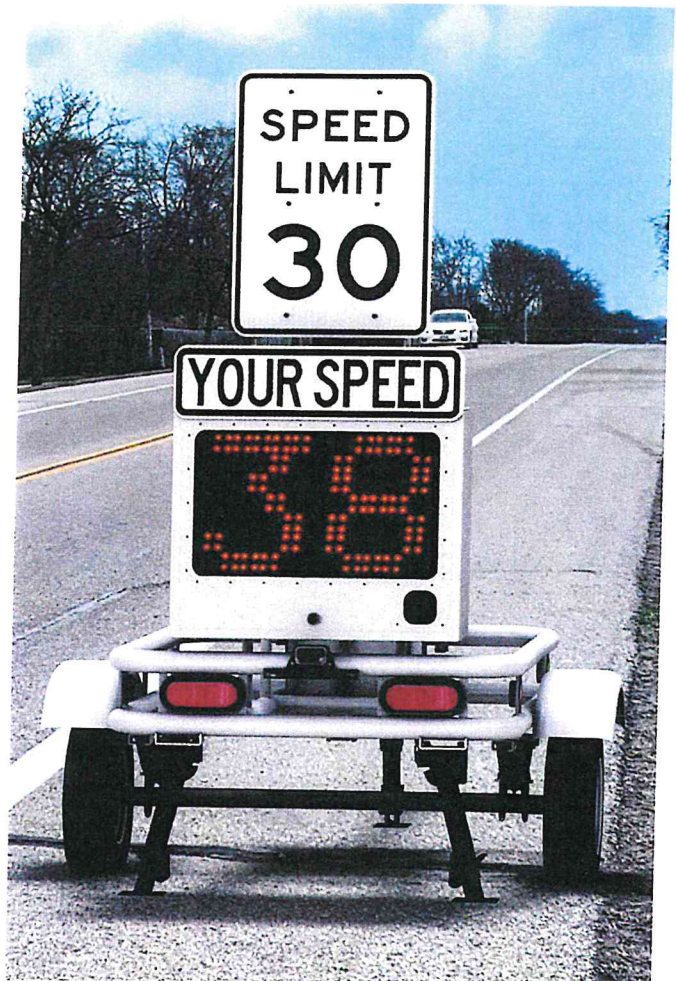

FAST-12T

Radar Speed Trailer

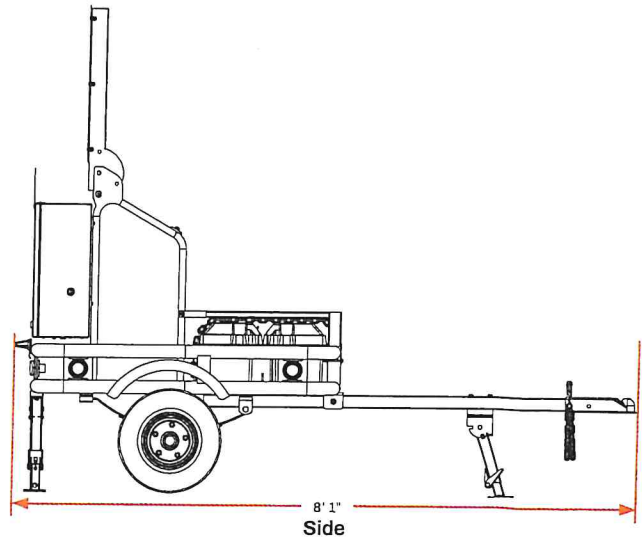
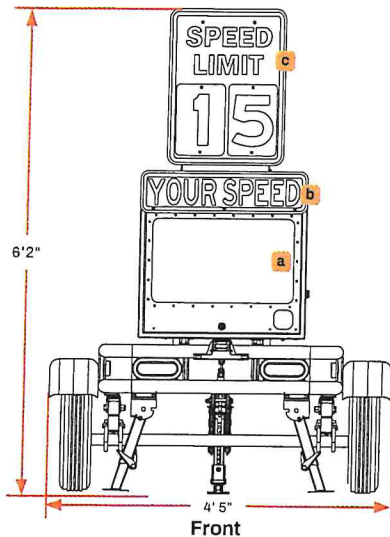

FAST-12T Speed Sign

Digit Size	12"
Viewing Angle	15 degrees
Viewing Distance	Up to 750 ft.
Speed Display Enclosure ^a	<p>Dimensions 26" x 20.5" x 8.75"</p> <p>Material 1/8" (0.125") thick welded aluminum</p> <p>Rating NEMA 3R</p>
Static Regulatory Sign ^b	<p>Dimensions 26" x 6" x 0.080"</p> <p>Material 5052 aluminum with 3M DG3 Sheeting</p>
Changeable Speed Limit Placard ^c	<p>Dimensions 18" x 24" x 0.080"</p> <p>8" Digit Overlays 0, 2, 3, 4</p> <p>Material 5052 aluminum with 3M DG3 Sheeting</p>
Radar	K-band single directional
Speed Violator Options	Flashing digits; "SLOW", white flashing strobe, red-blue flashing bars
Traffic Count Data Collection	<p>Data Storage Secure Data (SD) Card</p> <p>Reporting Vehicle count, survey summary, speed and time/date, 85th percentile, batch analysis (15 minute, 1 hour, daily or weekly)</p>
Agency Approvals	This device complies with Part 15 of the FCC Rules
Warranty	1-Year Limited Warranty

FAST-12T Trailer

Dimensions	96.5" x 53"
Weight	GVWR 650 lbs.
Height	<p>Deployed 74"</p> <p>In-Tow 52"</p>
Construction	2" tubular steel powder coated
Color	White (other colors available upon request)
Hitch	2" Class II ball coupler
Leveling	Three (3) leveling jacks - 3 flip down
Suspension	2000 lbs. axle, leaf spring suspension
Wheels/Tires	8" white steel wheels w/two (2) 4.80 x 8 ST rated tires
Battery	(2) 80Ah batteries standard
Battery Charger	5A internal marine grade floating charger
Solar Option	60W solar panel standard

Adaptive

Adaptive Micro Systems
7840 North 86th Street
Milwaukee, WI 53224

(800) 558-7022
www.adaptivedisplays.com
connect@adaptivedisplays.com



Designed and built in the USA using American and imported parts

TJ Graveley

From: Sydney Catania <sydney.catania@tapconet.com>
Sent: Tuesday, August 29, 2023 3:39 PM
To: TJ Graveley
Subject: RE: TAPCO Quote
Attachments: 50704 SSI Sales - Quote Q23013372.pdf; adaptive-fast-12t-radar-speed-trailer-sell-sheet-4-5-23 (1).pdf

Hi T.J.,

Please see attached quote for the FAST radar feedback trailer.
I have also attached a spec sheet.
Free freight with purchase.

Please let me know if you have any questions.

Thank you,

Sydney Catania

Account Manager - ND, SD, MT, NE, KS, WY, UT
262-649-5620

[Click Here](#) to schedule a meeting with me.

Take a look at our new [Resource Center](#) for case studies, webinars and other great information.

sydney.catania@tapconet.com

[Visit us at TAPCOnet.com](http://www.tapconet.com)



From: Sydney Catania
Sent: Tuesday, August 29, 2023 10:35 AM
To: tgraveley@co.broadwater.mt.us
Subject: TAPCO Quote

Hi T.J.,

Thank you for your quote request. I am working on this now for you.

Do you need a freight cost for the FAST radar speed trailer?

Best,

Sydney Catania

Account Manager - ND, SD, MT, NE, KS, WY, UT
262-649-5620

